

Technics

STEREO INTEGRATED AMPLIFIER

SU-VZ320

OPERATING INSTRUCTIONS



Notes:

- Specifications differ according to the area code.
- The "EB" area code, for example, indicates United Kingdom specifications.
- The "EB" indication is shown on the packing case and serial number tag.

Before operating this unit, please read these instructions completely.

Dear Stereo Fan

We want to thank you for selecting this product and to welcome you to the growing family of satisfied Technics product owners around the world. We feel certain you will get maximum enjoyment

from this new addition to your home. Please read these operating instructions carefully, and be sure to keep them handy for convenient reference.

Contents

• Accessory	2	• Technical Specifications	10
• For United Kingdom	2	• Protection Circuitry	10
• Connections	3	• Maintenance	10
• Front Panel Controls and Functions	5	• Suggestions for Safety	11
• Listening to the Sound	6	• Troubleshooting Guide	Back cover
• Recording	8		

CAUTION:

The AC voltage is different according to the area.
Be sure to set the proper voltage in your area before use.
(For details, please refer to the page 4.)

Accessory

- AC power supply cord 1

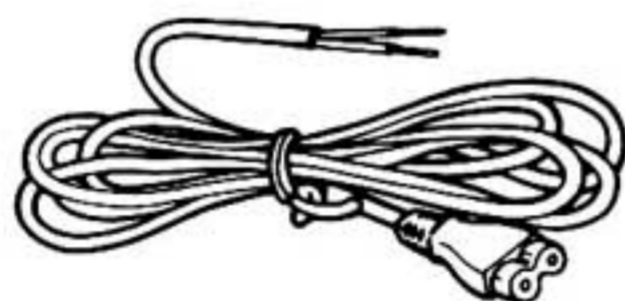

Configuration of the AC power supply cord differs according to area.

For United Kingdom ("EB" area code model only)

The "EB" indication is shown on the serial number tag.

Important

THE WIRES IN THIS MAINS LEAD ARE COLOURED IN ACCORDANCE WITH THE FOLLOWING CODE.

BLUE: NEUTRAL
BROWN: LIVE

As the colours of the wires in the mains lead of this apparatus may not correspond with the coloured markings identifying the terminals in your plug proceed as follows. The wire which is coloured BLUE must be connected to the terminal which is marked with the letter N or coloured BLACK.

The wire which is coloured BROWN must be connected to the terminal which is marked with the letter L or coloured RED.

Under no circumstances must either of the above wires be connected to the earth terminal of a three pin plug.

Connections

Make connections to each component in the system by using stereo connection cables (not included).

Stereo connection cable

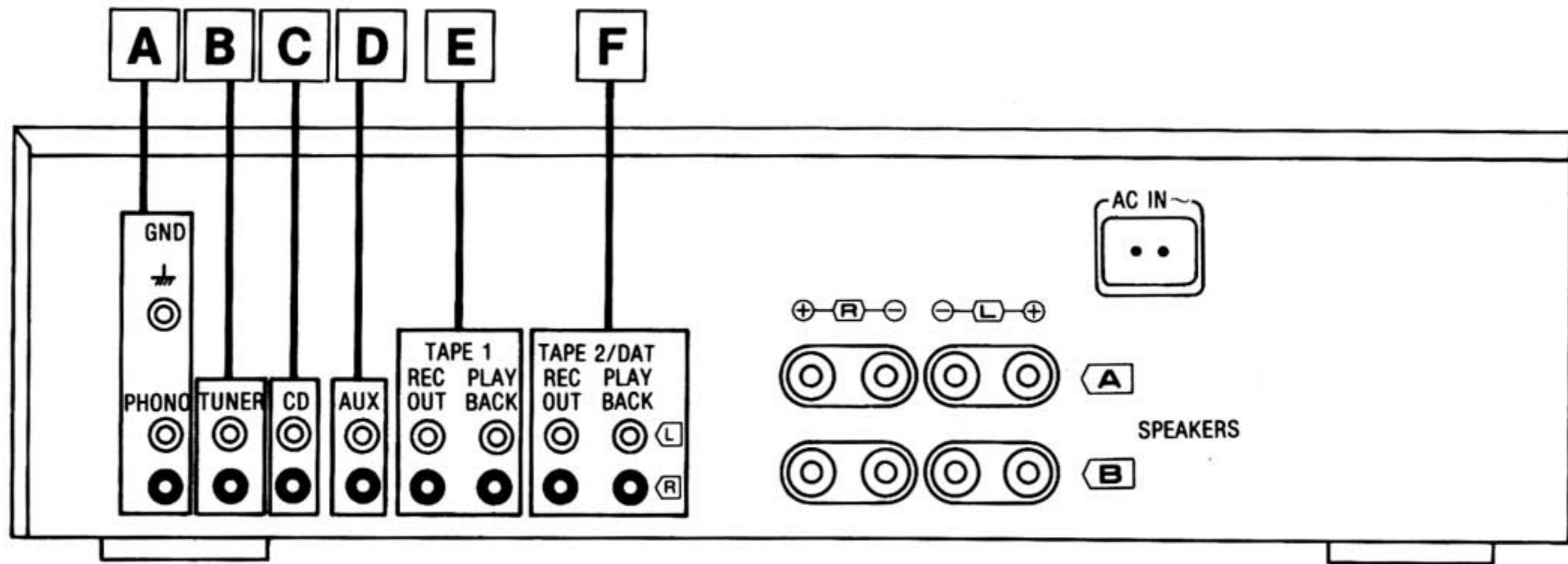

A "PHONO" terminals

Connect a turntable.

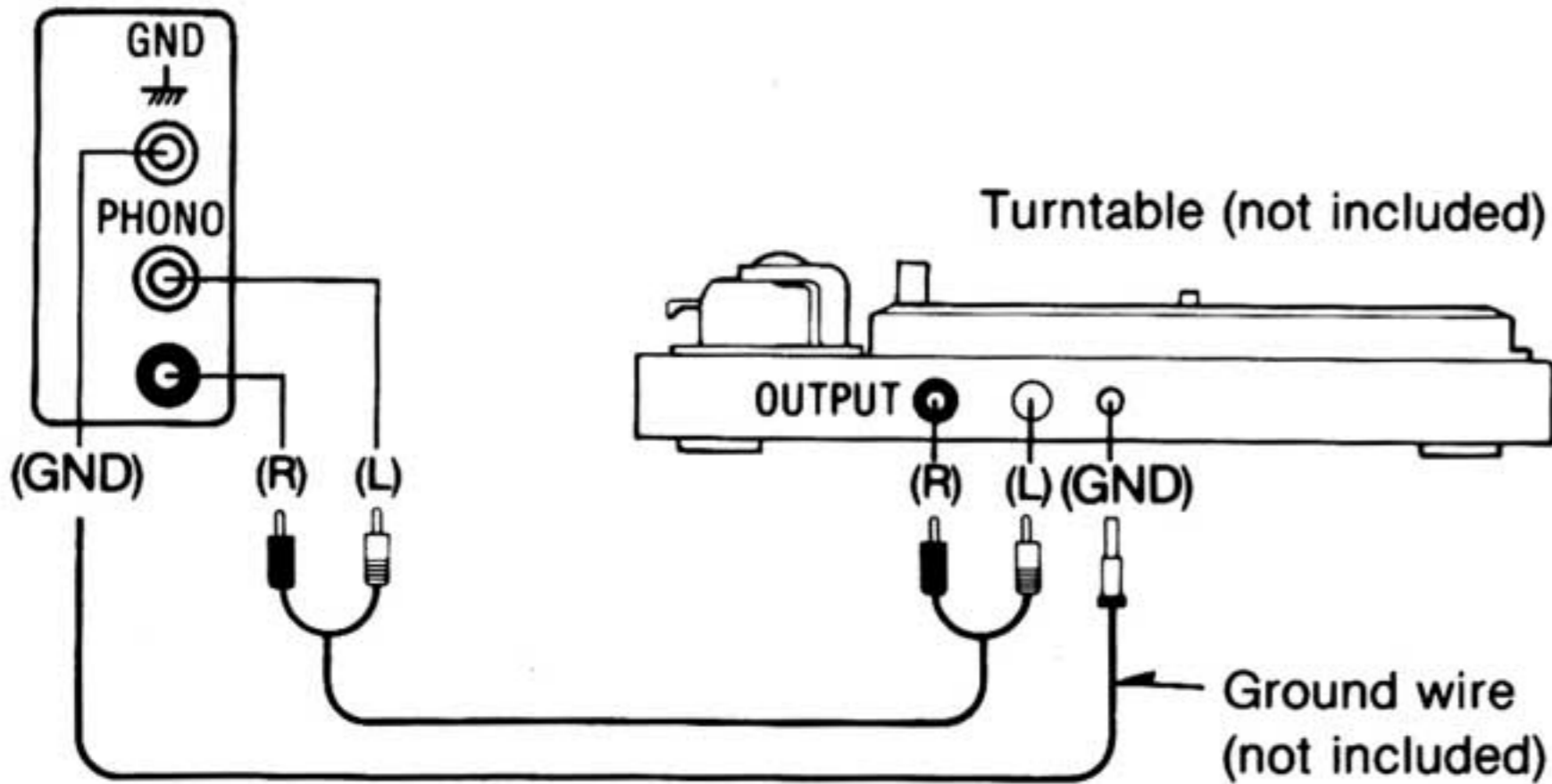

B "TUNER" terminals

Connect a tuner.

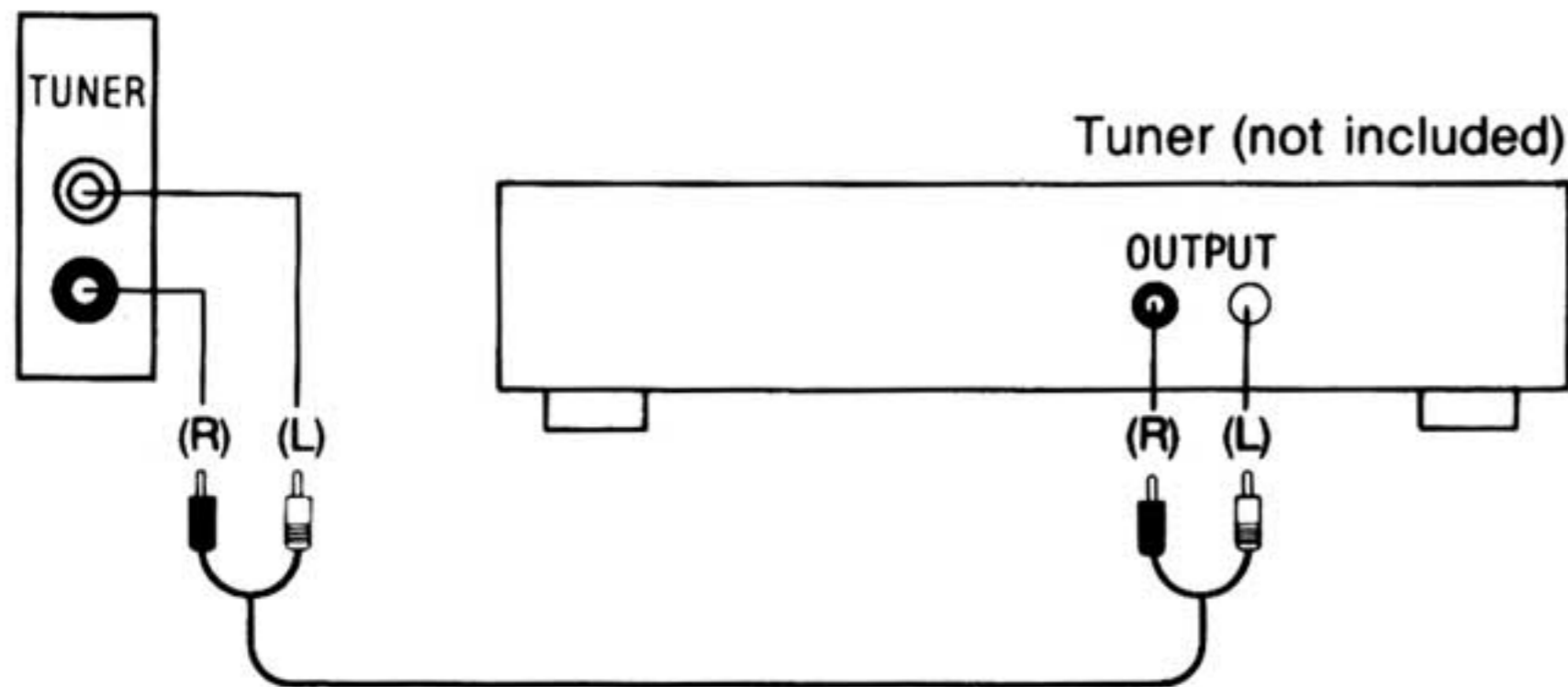

C "CD" terminals

Connect a compact disc player.

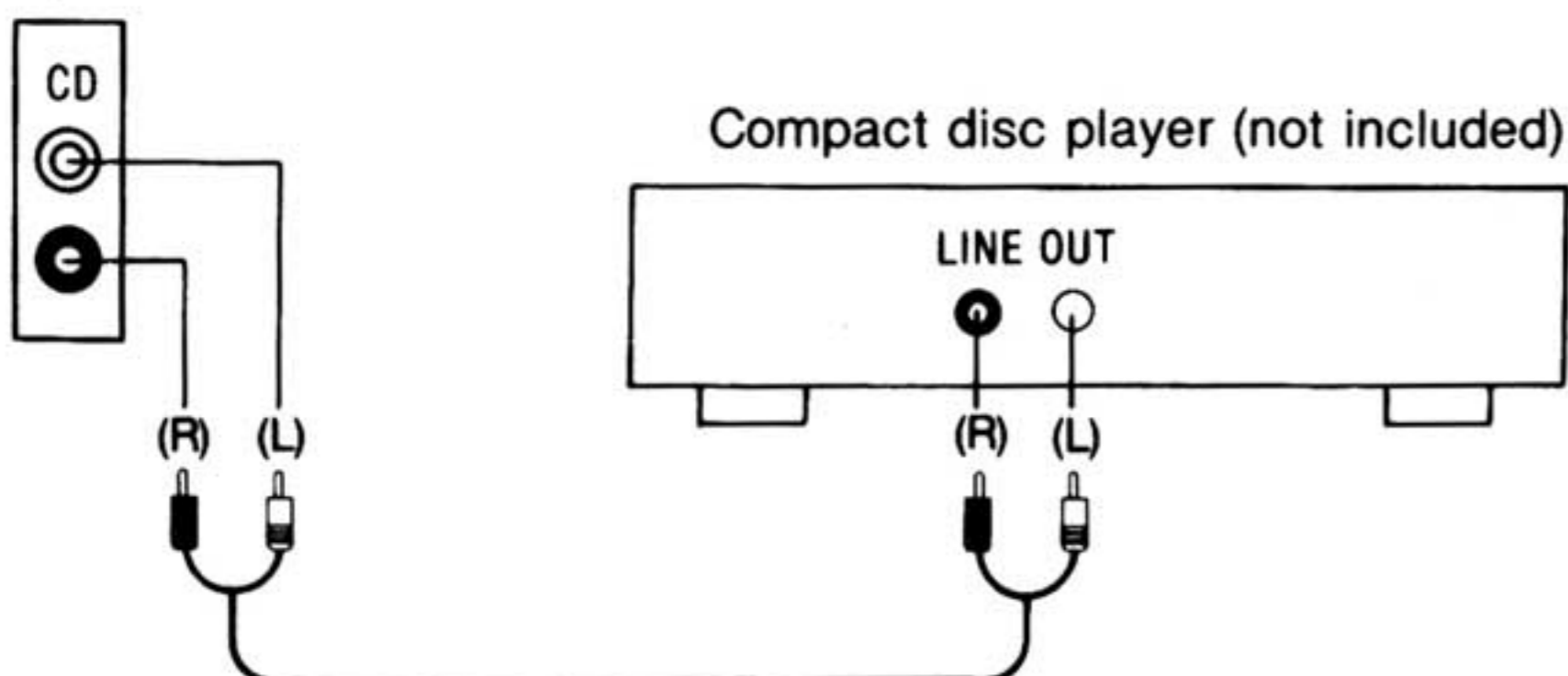

D "AUX" terminals

Connect a component such as a video disc player (audio only connectable), etc.

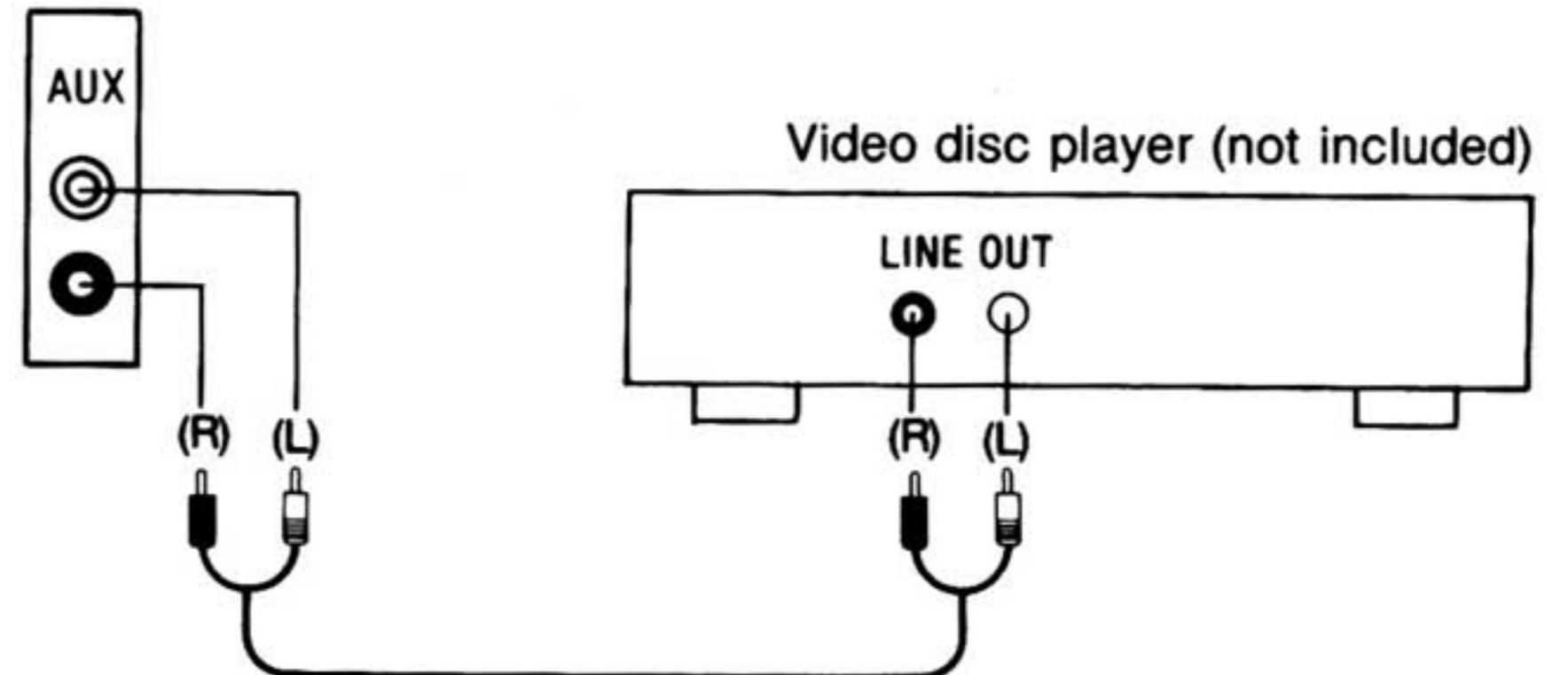

E "TAPE 1" terminals

Connect a first tape deck.

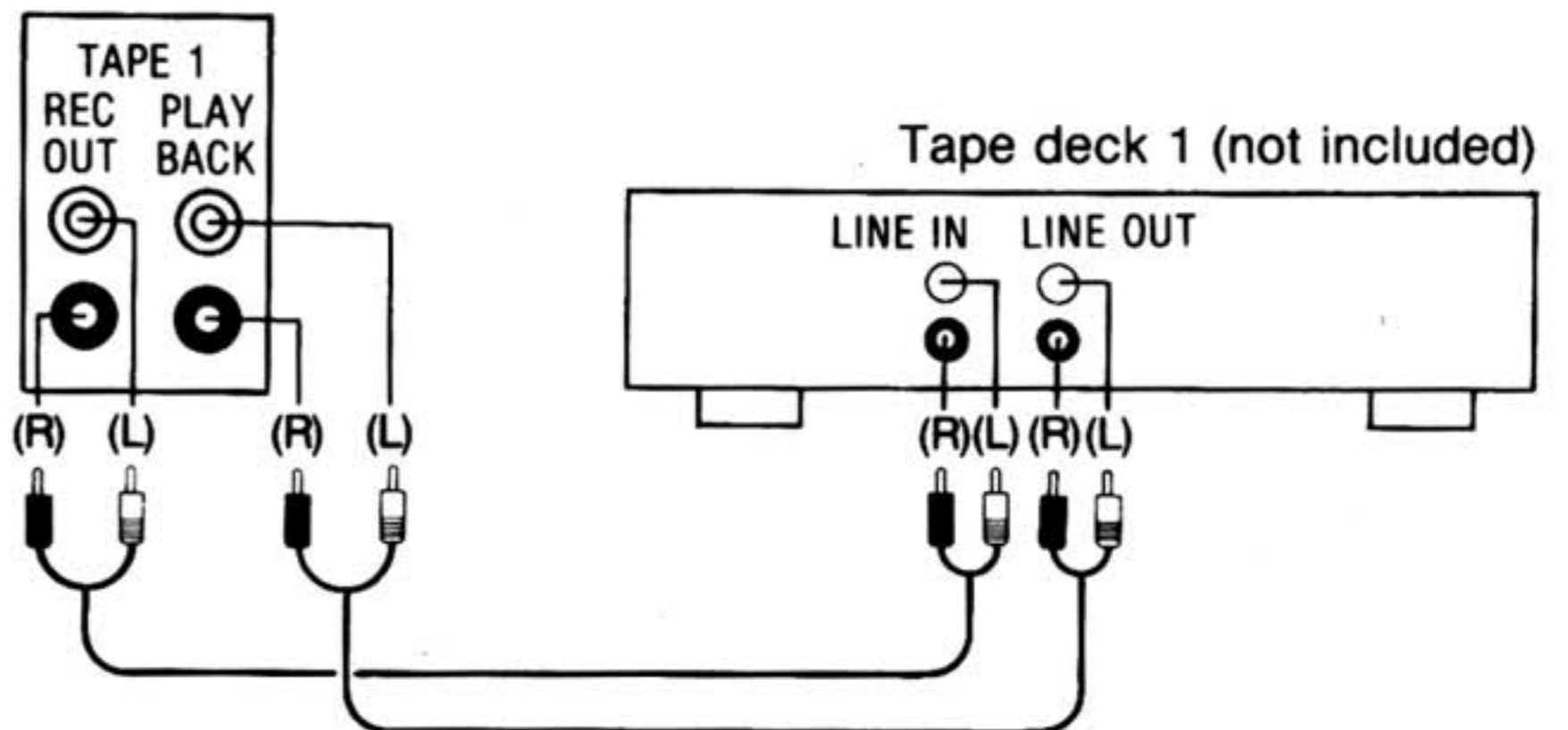

F "TAPE 2/DAT" terminals

Connect a second tape deck or a digital audio tape deck (DAT).

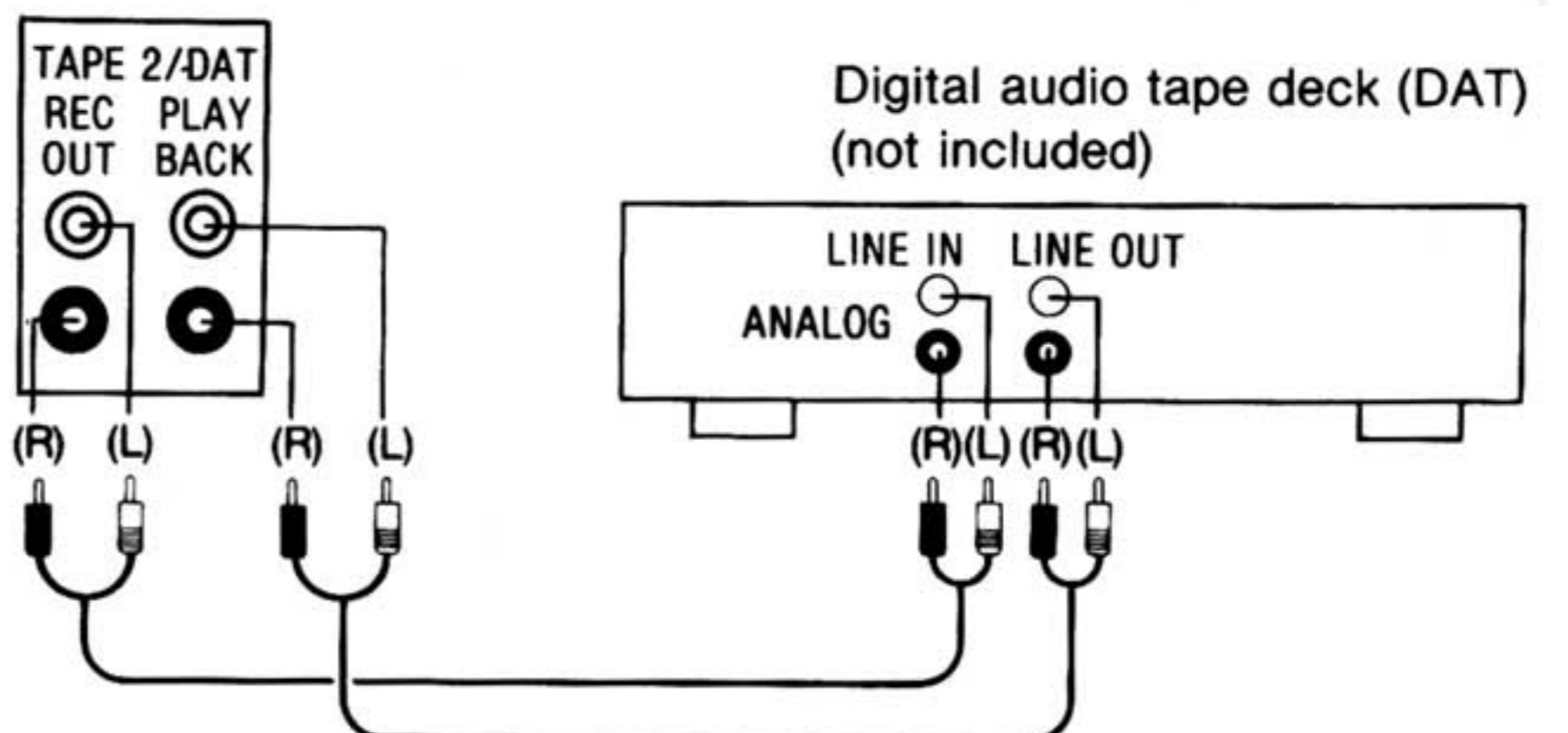

Connections (continued)

Connection to speaker systems

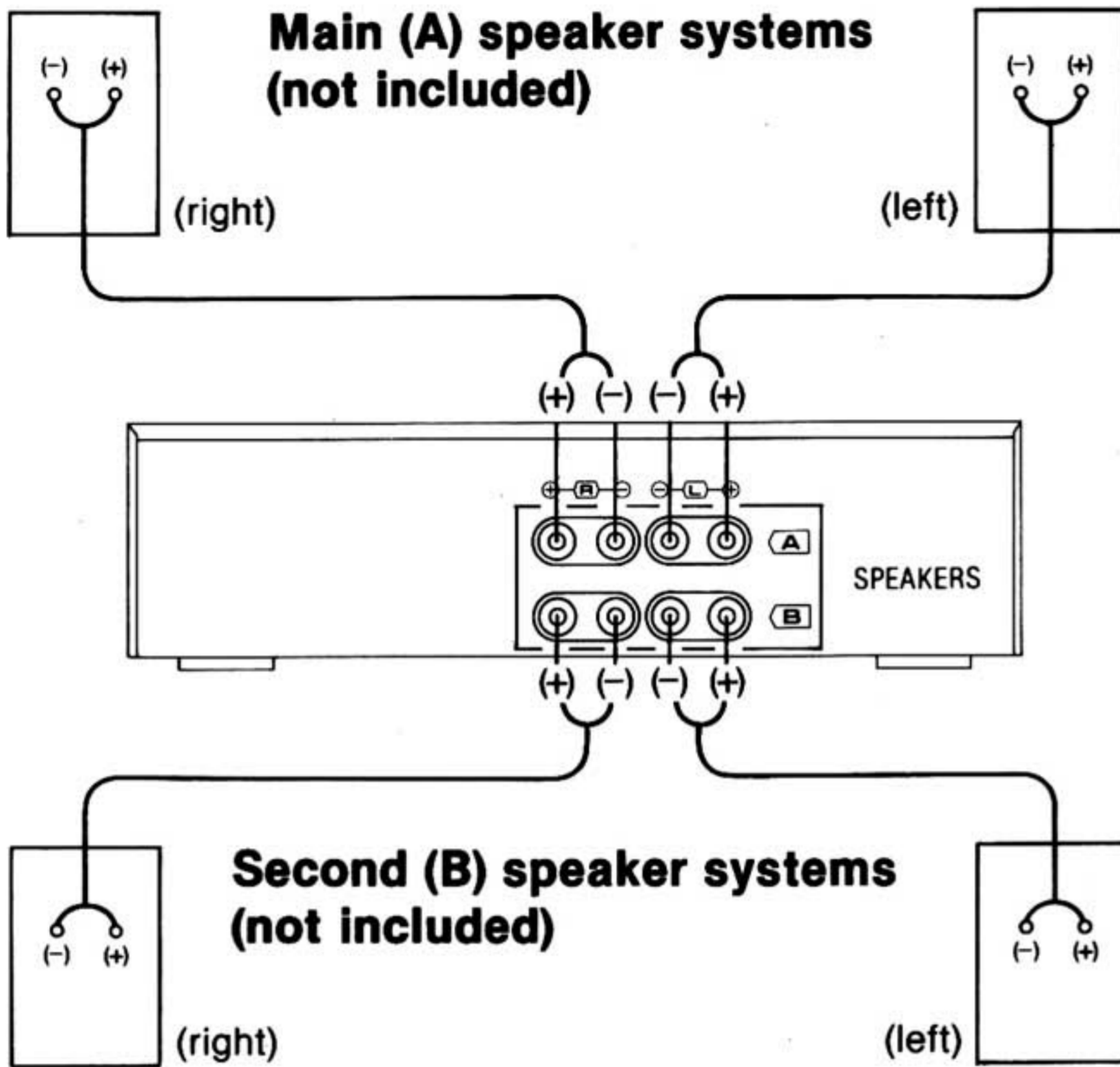

One pair of speaker systems can be connected to the "A" terminals of this unit and one pair to the "B" terminals. Make connections to each speaker system by using speaker cords (not included).



Load impedance

- When only the "A" or only the "B" terminals are used: 4–16 ohms
- When both the "A" and the "B" terminals are used simultaneously: 8–16 ohms

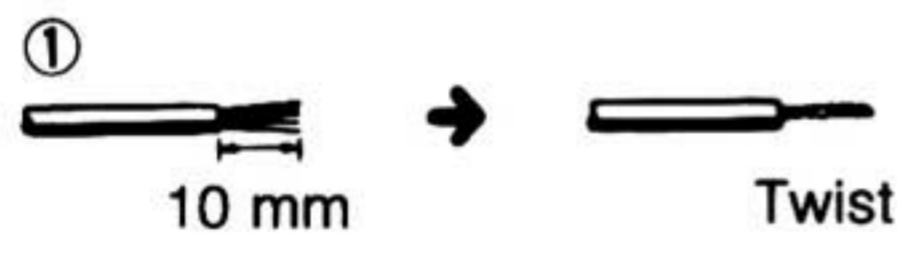
To connect cords to terminals

- ① Strip off the outer covering, and twist the center conductor. 
- ② Turn completely to the left. 
- ③ Insert the wire and turn completely to the right. Pull the cord to assure a proper connection. 

Note: Be sure to only connect positive (+) cords to positive (+) terminals, and negative (-) cords to negative (-) terminals.

Note:

To prevent damage to circuitry, never short-circuit the plus (+) and minus (-) speaker wires.



To set the power voltage

Set the voltage selector to the voltage setting for the area in which the unit will be used.

[Use a minus (-) screwdriver]

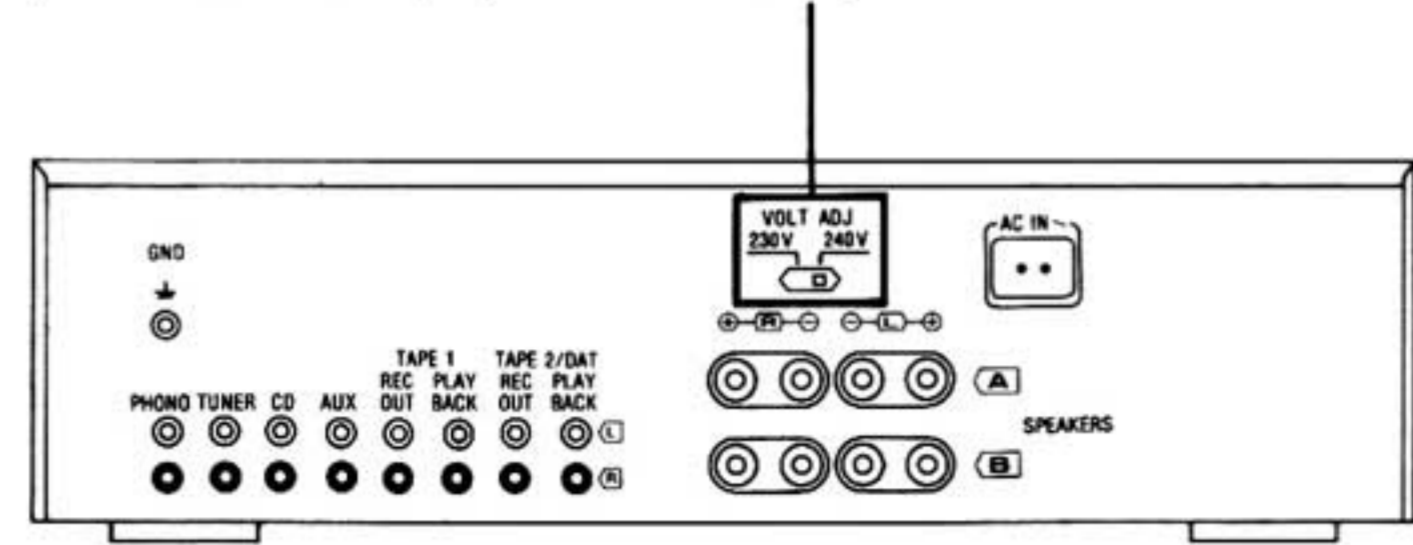

Note:

Note that this unit will be seriously damaged if this setting is not made correctly.

To connect the AC power supply cord (included)

Connect the AC power supply cord (included) after all other cables and cords are connected.

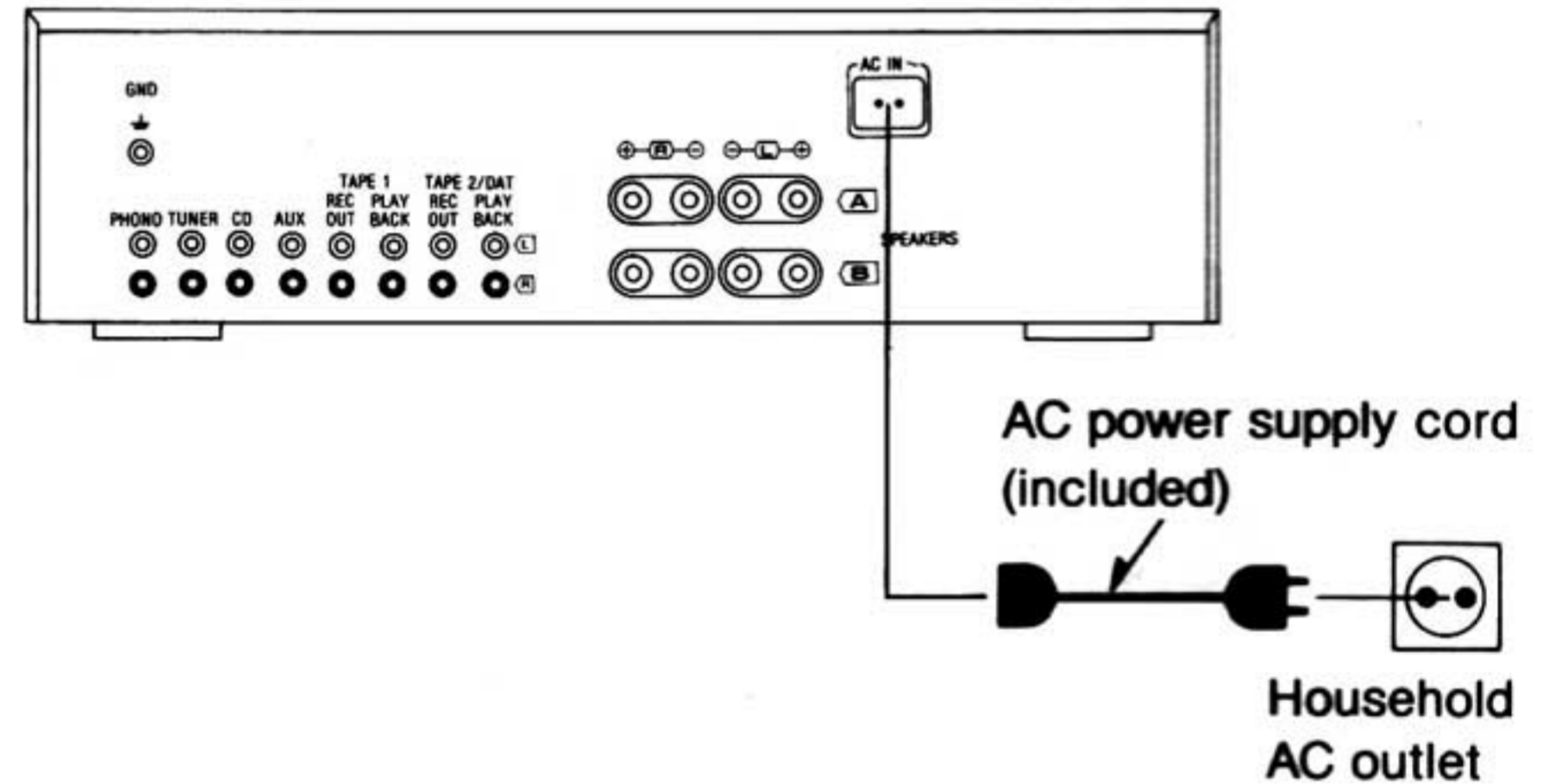

Note:

Configuration of AC power supply cord differs according to area.

For United Kingdom

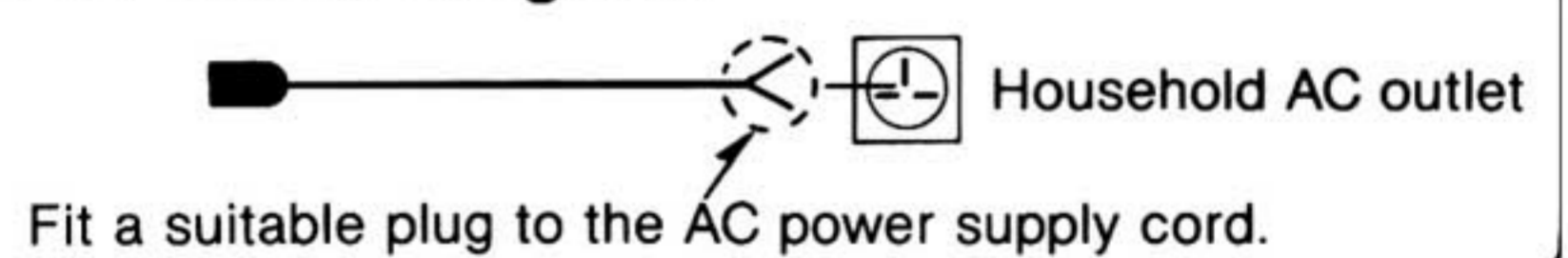

Front Panel Controls and Functions

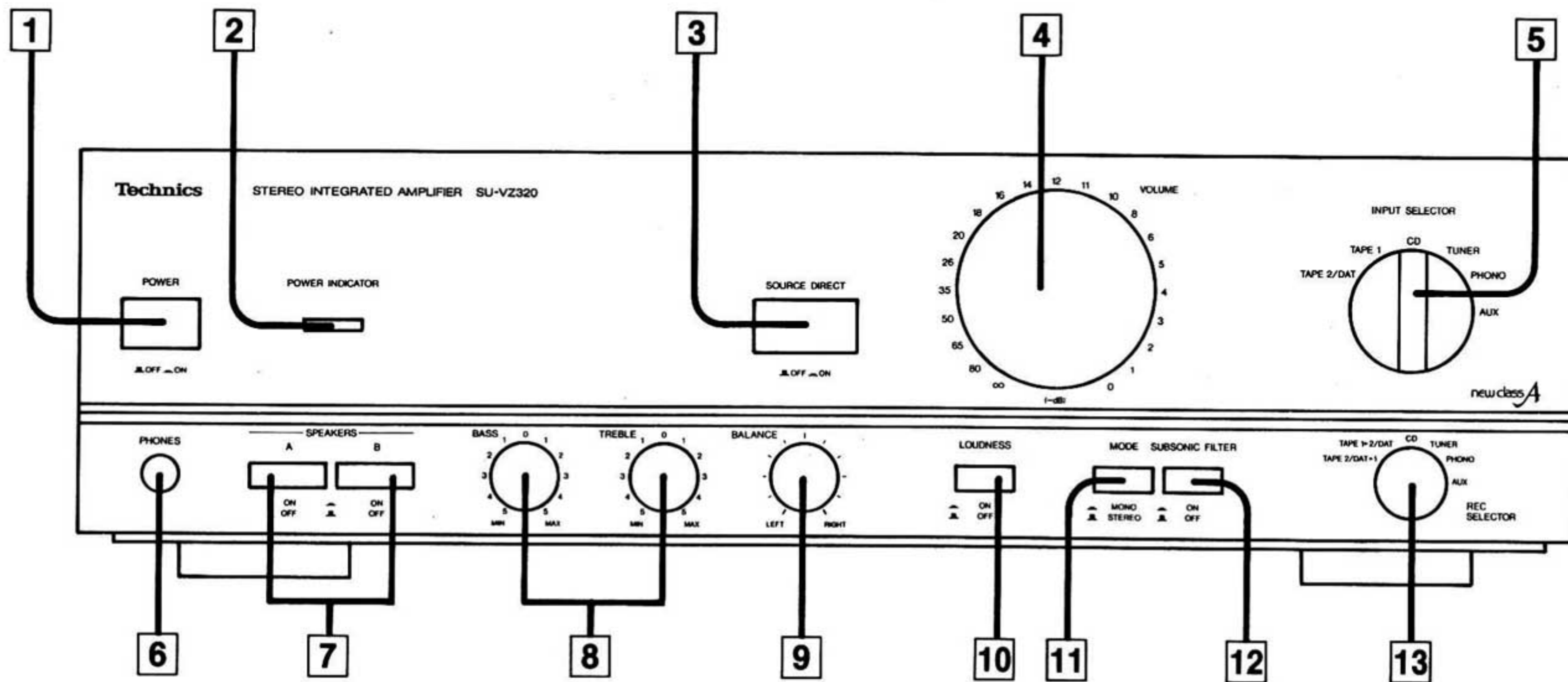

1 Power switch (POWER)

2 Power indicator (POWER INDICATOR)

When the power is switched ON, this indicator illuminates.

3 Source direct switch (SOURCE DIRECT)

This switch is used when enjoying high quality sound playback such as that from a CD.

4 Volume control (VOLUME)

5 Input selector (INPUT SELECTOR)

This selector is used to select the sound source to be heard, such as a disc, radio broadcast, etc.

6 Headphones jack (PHONES)

7 Speaker selectors (SPEAKERS)

These selectors are used to select the speaker systems to be used.

8 Tone controls (BASS/TREBLE)

The bass control is used to adjust the low-frequency sound range, and the treble control is used to adjust the high-frequency sound range.

9 Balance control (BALANCE)

This control is used to adjust the left/right volume balance.

10 Loudness switch (LOUDNESS)

This switch is used when listening to music at a low volume level. Auditory perception of sound in the low frequency range falls off at low volume, but when the switch is set to the "ON" position, this deficiency is compensated for, so that the full impact of the musical performance can be enjoyed.

11 Mode selector (MODE)

This selector is used to select stereo or monaural operation.

12 Subsonic filter switch (SUBSONIC FILTER)

This switch is used to eliminate ultra-low-frequency noise such as motor "rumble" and unusual vibration of the woofer cone caused by a warped disc, etc.

13 Recording selector (REC SELECTOR)

This selector is used to select the sound source to be recorded by the connected tape deck 1 and/or tape deck 2 (or DAT).

Listening to the Sound

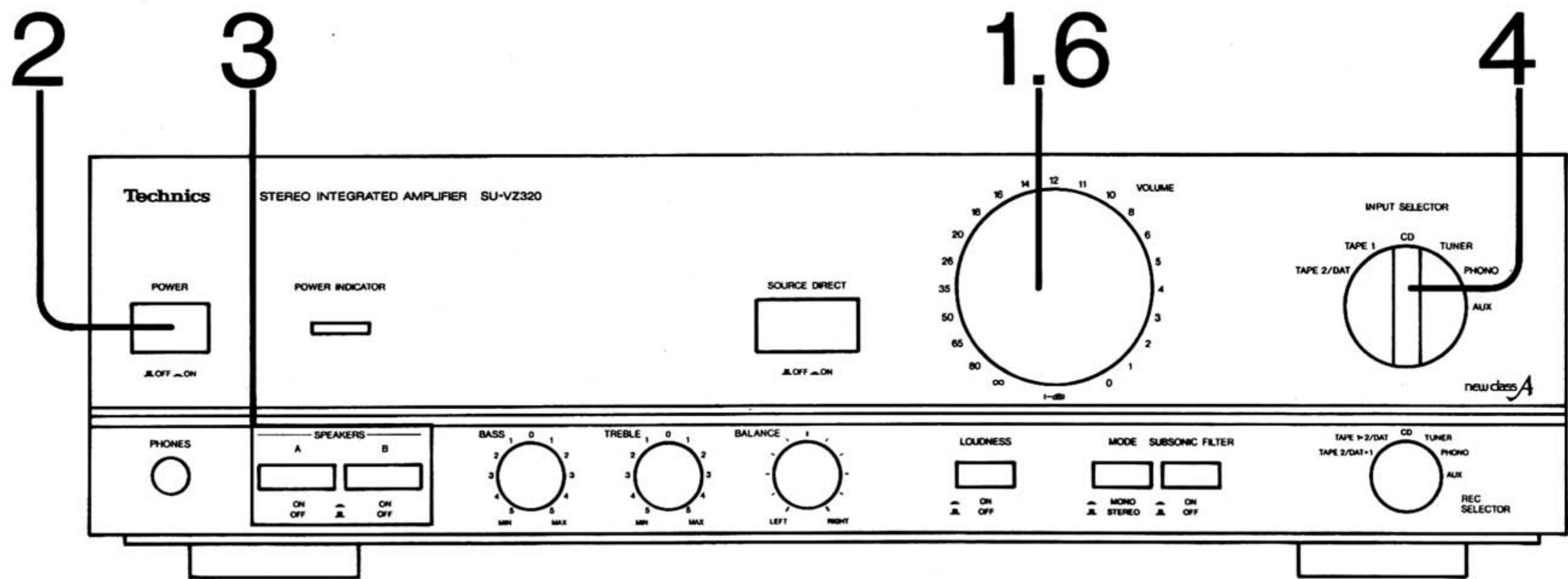

1 Set the volume control to the “∞” position.

2 Switch ON the power.

3 Select the speaker system (A, B or A + B) to be used.

4 Select the sound source.
TAPE 2/DAT: Set to this position to listen to equipment connected to the “TAPE 2/DAT” terminals.
TAPE 1: Set to this position to listen to the tapes.
CD: Set to this position to listen to compact discs.
TUNER: Set to this position to listen to radio broadcasts.
PHONO: Set to this position to listen to phono discs.
AUX: Set to this position to listen to equipment connected to the “AUX” terminals.

5 Begin operation of the components to be used.
 Refer to the operating instructions of each component.

6 Adjust the volume level.

While listening through headphones

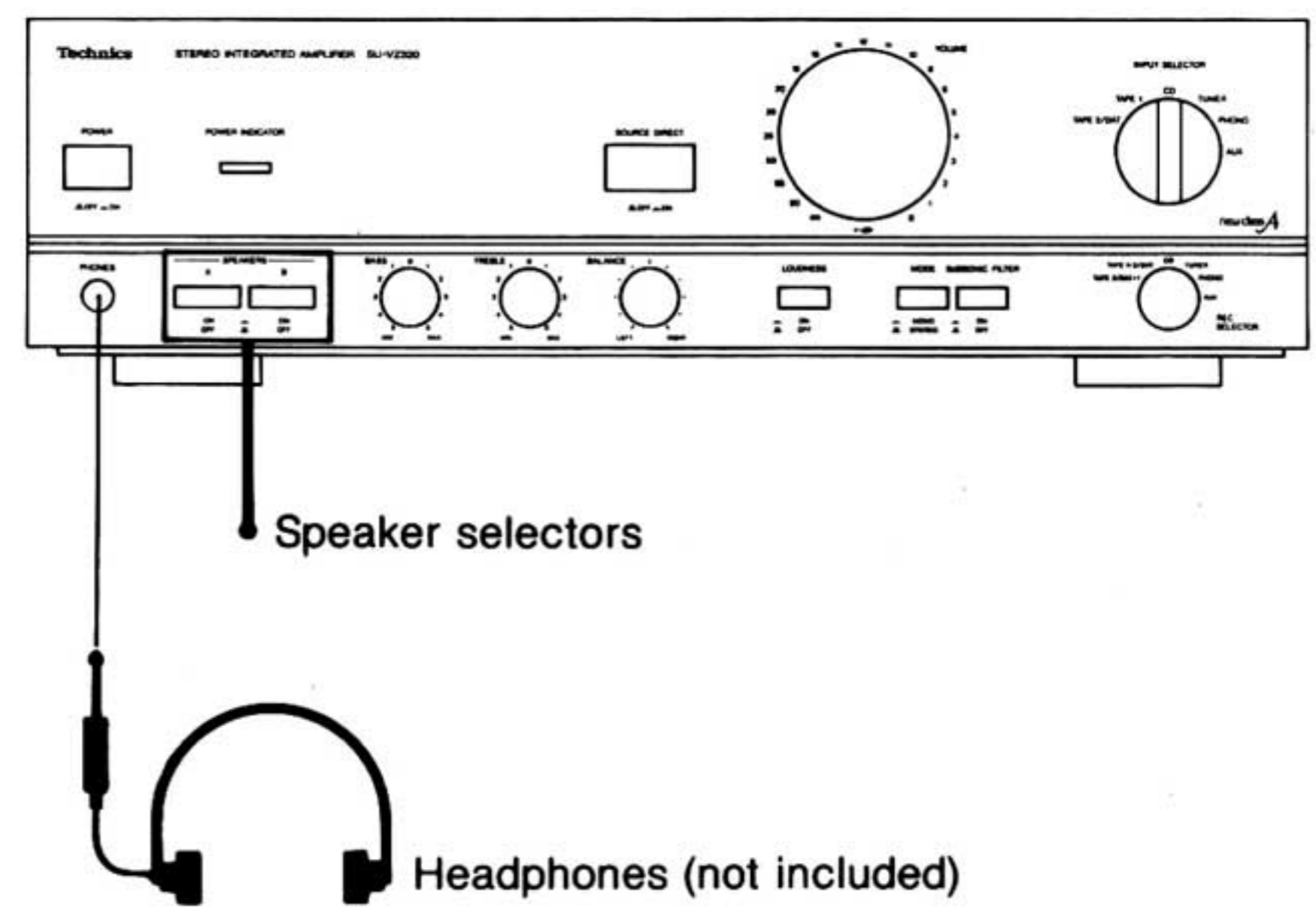

- Reduce the volume level before connecting headphones.
- If the sound from the speakers is not wanted, set the speaker selectors to the “OFF” position.
- Avoid listening for prolonged periods of time to prevent hearing damage.

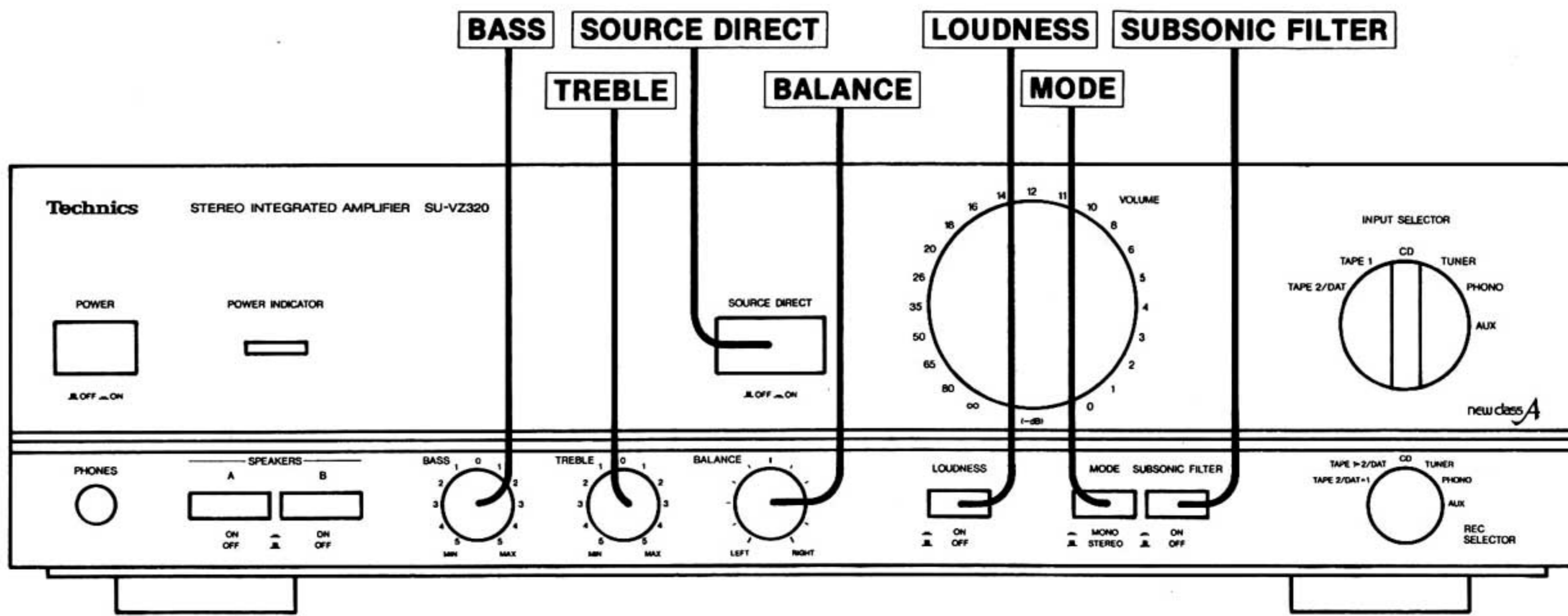

While listening to music

SOURCE DIRECT

Set this switch to "ON" to enjoy high quality sound playback such as that from a CD. When adjusting tone quality (BASS, TREBLE), set this switch to "OFF".

BASS

Adjust the low-frequency sound to the desired tone quality.

TREBLE

Adjust the high-frequency sound to the desired tone quality.

BALANCE

Adjust the balance for the left/right volume.

LOUDNESS

When listening to music at a low volume level, press the loudness switch inward to the "ON" position for compensation of the bass range.

MODE

Select the stereo or monaural operation.

STEREO (): Set to this position to listen in stereo.

MONO (): Set to this position to listen monaurally.

The left and right sounds will be mixed, and the same sounds will be heard from both speakers.

SUBSONIC FILTER

Set this switch to the "ON" position if you want to eliminate ultra-low-frequency noise such as motor "rumble" and unusual vibration of the woofer cone caused by a warped disc, etc.

After listening is finished

Use the volume control to reduce the volume level and switch OFF the power of each unit.

Recording

Note:

Tape deck 1 is the tape deck connected to the "TAPE 1" terminals.

Tape deck 2 is the tape deck connected to the "TAPE 2/DAT" terminals.

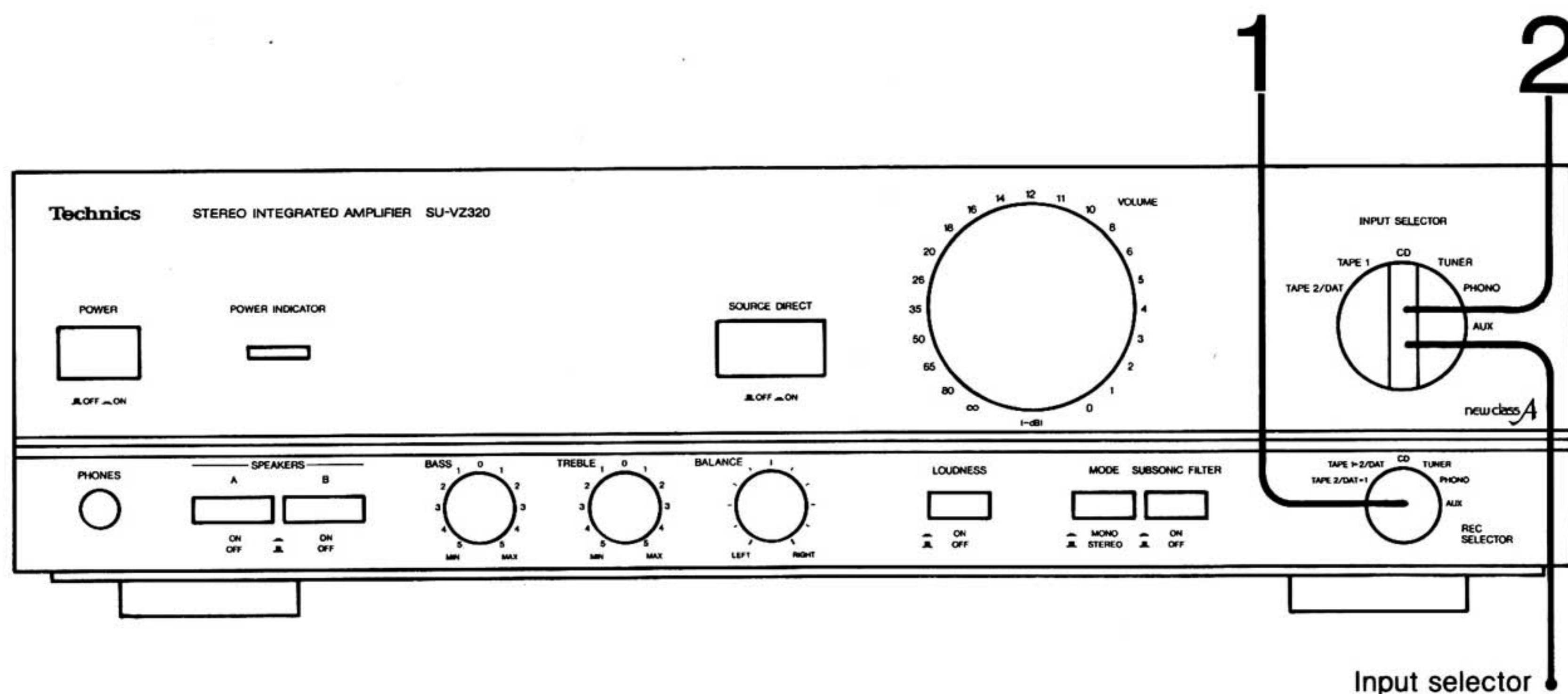

To record from compact discs, etc.

1 Select the program source to be recorded.

CD: Set to this position to record from compact discs.

TUNER: Set to this position to record from radio broadcasts.

PHONO: Set to this position to record from phono discs.

AUX: Set to this position to record from equipment connected to the "AUX" terminals.

■ To listen to a source other than the one now being recorded ...

Select the source by using the input selector.

2 Set the input selector to the same position as the recording selector has been set.

■ To check the sound recorded

With a tape deck with 3 heads, it is possible to check the sound recorded on the tape.

3 Start recording, and play back the source.

(Refer to the operating instructions for the tape deck for detailed operation of the recording level adjustment.)

Set the input selector to "TAPE 1" or "TAPE 2/DAT" and the monitor switch on the tape deck to "TAPE".

"TAPE 1": when recording on tape deck 1.

"TAPE 2/DAT": when recording in tape deck 2.

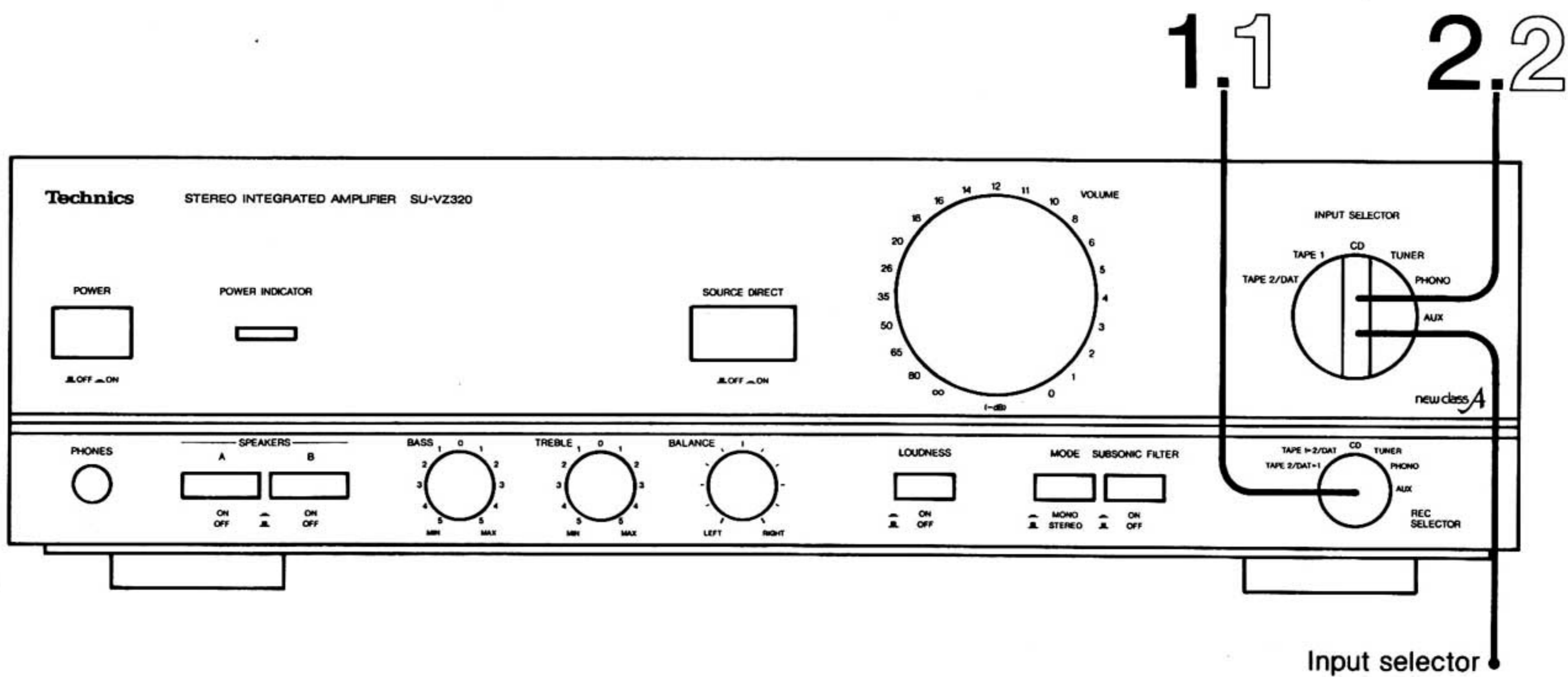

Tape-to-tape recording

Tape-to-tape recordings can be made if two regular tape decks, or one regular tape deck and a digital audio tape (DAT) deck, are connected to the rear panel of this unit.

To record from tape deck 2 (or DAT) to 1

- 1 Set the recording selector to "TAPE 2/DAT ▶ 1".
- 2 Set the input selector to "TAPE 2/DAT".
- 3 Start the tape deck 1 for recording and the tape deck 2 (or DAT) for playback.

To record from tape deck 1 to 2 (or DAT)

- 1 Set the recording selector to "TAPE 1 ▶ 2/DAT".
- 2 Set the input selector to "TAPE 1".
- 3 Start the tape deck 2 (or DAT) for recording and the tape deck 1 for playback.

■ To listen to a source other than the one now being recorded...

Select the source by using the input selector.

■ To check the sound recorded

With a tape deck with 3 heads, it is possible to check the sound recorded on the tape.

Set the input selector to "TAPE 1" or "TAPE 2/DAT" and the monitor switch on the tape deck to "TAPE".

"TAPE 1": when recording from tape deck 2 (or DAT) to 1.

"TAPE 2/DAT": when recording from tape deck 1 to 2.

Technical Specifications (DIN 45 500)

20 Hz~20 kHz continuous power output both channels driven	2 × 40 W (8 Ω)
1 kHz continuous power output both channels driven (THD:1%)	2 × 50 W (8 Ω) 2 × 75 W (4 Ω)
63 Hz~12.5 kHz continuous power output both channels driven (THD: 0.7%)	2 × 45 W (8 Ω) 2 × 65 W (4 Ω)
Total harmonic distortion rated power at 20 Hz~20 kHz	0.02% (8 Ω)
rated power at 1 kHz	0.007% (8 Ω)
half power at 20 Hz~20 kHz	0.02% (8 Ω)
half power at 1 kHz	0.007% (8 Ω)
Intermodulation distortion (50 Hz:7 kHz = 4:1, SMPTE) rated power	0.02% (8 Ω)
Residual hum and noise	1 mV
Damping factor	40 (8 Ω) 20 (4 Ω)
Headphones output level and impedance	450 mV/330 Ω
Load impedance A or B	4~16 Ω
A and B	8~16 Ω
Input sensitivity and impedance PHONO MM	2.5 mV/47 kΩ
TUNER, CD, AUX, TAPE 1, TAPE 2/DAT	150 mV/22 kΩ
Phono maximum input voltage (1 kHz, RMS) MM	150 mV (150 mV, IHF '66)
S/N (rated power, 4 Ω) PHONO MM	76 dB (79 dB, IHF '66)
TUNER, CD, AUX, TAPE 1, TAPE 2/DAT	91 dB (99 dB, IHF '66)
S/N at -26dB power (4 Ω) PHONO MM	68 dB
TUNER, CD, AUX, TAPE 1, TAPE 2/DAT	70 dB
S/N at 50 mW power (4 Ω) PHONO MM	64 dB
TUNER, CD, AUX, TAPE 1, TAPE 2/DAT	64 dB

Frequency response PHONO MM	RIAA standard curve ±1 dB (30 Hz~15 kHz)
TUNER, CD, AUX, TAPE 1, TAPE 2/DAT	3 Hz~80 kHz (+0, -3 dB) +0 dB, -0.3 dB (20 Hz~20 kHz)
Tone controls BASS	50 Hz, +10~-10 dB
TREBLE	20 kHz, +10~-10 dB
Subsonic filter	30 Hz, -6 dB/oct
Loudness control (volume at -30 dB)	50 Hz, +9 dB
Output voltage TAPE 1, TAPE 2/DAT REC OUT	150 mV
Channel balance (AUX, 250 Hz~6.3 kHz)	±1 dB
Channel separation (AUX, 1 kHz)	50 dB

■ GENERAL

Power consumption	175 W
Power supply	AC 50 Hz/60 Hz, 230 V/240 V
Dimensions (W × H × D)	430 × 125 × 320 mm
Weight	7.3 kg

Notes:

1. Specifications are subject to change without notice.
Weight and dimensions are approximate.
2. Total harmonic distortion is measured by the digital spectrum analyzer.

This apparatus was produced to BS 800.

Protection Circuitry

The protection circuitry may have operated if either of the following conditions is noticed:

- No sound is heard when the power is switched ON.
- Sound stops during a performance.

The function of this circuitry is to prevent circuitry damage if, for example, the positive and negative speaker connection wires are "shorted", if speaker systems with an impedance less than the indicated rated impedance of this unit are used, or if DC voltage appears in the output.

If this occurs, follow the procedure outlined below:

1. Switch OFF the power.
2. Determine the cause of the problem and correct it.
3. Switch ON the power once again.

Note:

When the protection circuitry functions, the unit will not operate unless the power is first switched OFF and then ON again.

Maintenance

To clean this unit, use a soft, dry cloth.
For very dirty surfaces, dip a soft cloth in a weak soap-and-water solution and wring well. After cleaning, wipe with a soft, dry cloth.

Never use alcohol, paint thinner, benzene, or a chemically treated cloth to clean this unit.
Such chemicals may damage the unit's finish.

Suggestions for Safety

■ Use a standard AC wall outlet

1. **Use from an AC power source of high voltage, such as for an air conditioner, is very dangerous.**

There is the possibility that a fire might be caused by making such a connection.

2. **A DC power source cannot be used.**

Be sure to check the power source carefully, especially on a ship or other place where DC is used.

■ Grasp the plug when disconnecting the power supply cord

1. **Wet hands are dangerous.**

A dangerous electric shock may result if the plug is touched by wet hands.

2. **Never place heavy items on top of the power supply cord, and never force it to bend sharply.**

■ Place the unit where it will be well ventilated

Place this unit at least 10 cm (4") away from wall surfaces, etc. Be careful that curtains and similar materials do not obstruct the ventilation holes.

■ Avoid places such as the following:

In direct sunlight or in other places where the temperature is high.

In places where there is excessive vibration or humidity.

Such conditions might damage the cabinet and/or other component parts and thereby shorten the unit's service life.

■ Be sure to place the unit on a flat, level surface

If the surface is inclined, a malfunction may result.

■ Never attempt to repair or reconstruct this unit

A serious electric shock might occur if this unit is repaired, disassembled or reconstructed by unauthorized persons, or if the internal parts are accidentally touched.

■ Take particular care if children are present

Never permit children to put anything, especially metal, inside this unit. A serious electric shock or malfunction could occur if articles such as coins, needles, screwdrivers, etc. are inserted through the ventilation holes, etc. of this unit.

■ If water is spilled on the unit

Be extremely careful if water is spilled on the unit, because a fire or serious electric shock might occur. Immediately disconnect the power cord plug, and consult with your dealer.

■ Avoid spray-type insecticides

Insecticides might cause cracks or "cloudiness" in the cabinet and plastic parts of this unit. The gas used in such sprays might, moreover, be ignited suddenly.

■ Never use alcohol or paint thinner

These and similar chemicals should never be used, because they might cause flaking or cloudiness of the cabinet finish.

■ Disconnect the power supply cord if the unit will not be used for a long time

If the unit is left for a long time with the power ON, this will not only shorten its useful operation life, but may also cause other troubles.

■ If trouble occurs

If, during operation, the sound is interrupted or indicators no longer illuminate, or if abnormal odor or smoke is detected, immediately disconnect the power cord plug, and contact your dealer or an Authorized Service Center.

Troubleshooting Guide

Before requesting service for this unit, check the chart below for a possible cause of the problem you are experiencing. Some simple checks or a minor adjustment on your part may eliminate the problem and restore proper operation.

If you are in doubt about some of the check points, or if the remedies indicated in the chart do not solve the problem, refer to the directory of Authorized Service Centers (enclosed with this unit) to locate a convenient service center, or consult your Technics dealer for instructions.

Problem	Probable cause(s)	Suggested remedy
Problems noted at all times		
No sound is heard when the power is switched ON.	The power cord plug is not completely inserted.	<ul style="list-style-type: none"> • Confirm that the power cord plug is connected completely.
	Connections to the speaker systems, etc. are incomplete or incorrect.	<ul style="list-style-type: none"> • Check to be sure that all connection wires are correctly connected.
	The input selector's setting is incorrect.	<ul style="list-style-type: none"> • Check to be sure that the selection of the desired sound source is made correctly.
	The speaker selectors are set incorrectly.	<ul style="list-style-type: none"> • Set them to the correct position.
When listening to stereo sound, the sound lacks depth (i.e. thin bass, tinny sound).	One of the speakers is connected out of phase [(+)→(-), (-)→(+)].	<ul style="list-style-type: none"> • Reconnect the speakers maintaining proper polarity [i.e., (+)→(+), (-)→(-)].
When listening to stereo sound, the left and right sounds are reversed.	The left and right speaker connections, source connections, or graphic equalizer connections are reversed.	<ul style="list-style-type: none"> • Check all connections and correct them if necessary.
A low-pitched noise ("hum" or "buzz") is heard.	The power cord or a fluorescent light, etc., is near the connection wires.	<ul style="list-style-type: none"> • Try separating this unit as far as possible from the electric appliance.
Sound is not heard from one of the speaker systems.	The speaker wires are disconnected.	<ul style="list-style-type: none"> • Check and correct the connections of the speaker wires.
	The balance control is set too far to one side.	<ul style="list-style-type: none"> • Set so that sounds are heard at the center, between the speaker systems.
Sound stops during a performance, or no sound is heard when the power is switched ON.	The protection circuitry has functioned because the positive and negative speaker connection wires are "shorted" or speaker systems with an impedance less than the indicated rated impedance of the amplifier are used.	<ul style="list-style-type: none"> • Switch OFF the power, and, after determining and correcting the cause, switch ON the power once again. • Use a speaker system of the proper impedance rating.